



***NV3064 Instruction Manual***

---

***AES/EBU Digital Audio  
Routing Switcher***

Manual Part Number: MN3064-01A  
December 1999



125 Crown Point Court, Grass Valley, CA 95945, USA  
Telephone: (530) 265-1000, FAX: (530) 265-1021  
Web Site - <http://www.nvision1.com/>

## Revision History: P/N MN3064-01

Date	Revision Number and Notes
December 1999	Revision A, Initial Release. Includes EM0134 and UniDiag.

## Warranty

NVISION, Inc. warrants that the equipment it manufactures shall be free from defects in materials and workmanship for a period of two (2) years, optionally extendable to five (5) years, from the date of shipment from the factory. If warranted equipment fails due to such defects, NVISION, Inc. shall, at its option, repair or provide replacement for the defective part or product.

Equipment that fails after the warranty period, or that which has been operated outside its ratings or subjected to abuse or modification, shall be repaired for time and material charges at the Buyer's expense. All out-of-warranty repairs are warranted for a period of ninety (90) days from the date of shipment from the factory.

NVISION, Inc. makes no warranties, expressed or implied, of merchantability, fitness for a particular purpose or otherwise. With respect to the products sold by it, NVISION's liability for any cause, including breach of contract, breach of warranty or negligence, is limited to repair or replacement by NVISION, at its sole discretion. This remedy is exclusive.

In no event shall NVISION be liable for any incidental or consequential damages, including loss of profit.

© NVISION, Inc., 1999

No part of this manual may be reproduced in any form by photostat, microfilm, xerography or any other means, or incorporated into any information retrieval system, electronic or mechanical, without the written permission of NVISION, Inc.

The information contained in this manual is subject to change without notice or obligation.

\*All brand names and product names used in this book are the trademarks of their respective owners.

NVISION and UniDiag are trademarks of NVISION, Inc.

Printed in United States of America, 12/99

# Contents

Warranty . . . . . ii

## Preface

Quick Start . . . . . vii

Important Safeguards and Notices . . . . . viii

    Symbols and Their Meanings . . . . . viii

    Warnings . . . . . ix

    Cautions . . . . . x

    North American Power Supply Cords . . . . . xi

    International Power Supply Cords . . . . . xi

FCC (USA) Compliance Statement . . . . . xii

    FCC Emission Limits . . . . . xii

European Community (CE)  
Declaration of Conformance . . . . . xii

Year 2000 Warranty Statement . . . . . xiii

    Disclaimer . . . . . xiii

Technical Support . . . . . xiv

## Section 1: General Description

Receiving Inspection . . . . . 1-2

Unpacking Instructions . . . . . 1-2

Product Overview . . . . . 1-3

    Features . . . . . 1-4

Specifications . . . . . 1-5

## Section 2: Installation

Installing the NV3064 Router . . . . .	2-2
Tools and Materials Required . . . . .	2-2
Installing the Frame . . . . .	2-2
Inserting Cards into the Frame . . . . .	2-4
Required Jumper Settings . . . . .	2-5
PS2001 Power Supply Card Line Voltage Jumper . . . . .	2-5
Universal Control Card AES Ref Termination Jumper . . . . .	2-6
Asynchronous I/O Card Jumpers . . . . .	2-7
AES Synchronous I/O Card Jumpers . . . . .	2-8
Connecting Cables to the NV3064 Router . . . . .	2-10
RS-422 and RS-232 Connector Pin-Outs . . . . .	2-12
Connecting to Phoenix Connectors . . . . .	2-12
AC Power Connection . . . . .	2-13
Fuses . . . . .	2-14
Configuring the NV3064 Router for Use. . . . .	2-15

## Section 3: Operation

Introduction. . . . .	3-2
-----------------------	-----

## Section 4: Theory of Operation

NV3064 Router System Overview . . . . .	4-2
I/O Cards . . . . .	4-4
Control Card . . . . .	4-4
Crosspoint Matrix Card . . . . .	4-5
Power Supply . . . . .	4-6

## **Section 5: Maintenance**

Routine Maintenance . . . . .	5-2
Universal Control Module . . . . .	5-2
I/O Module . . . . .	5-3
Crosspoint Matrix Module . . . . .	5-3
Power Supply Module . . . . .	5-4
Fuses . . . . .	5-4
Diagnostic Software . . . . .	5-5
Adjustments . . . . .	5-5
Troubleshooting and Repair . . . . .	5-6
Ordering Replacement Assemblies . . . . .	5-8

## **Section 6: Notes**

Introduction . . . . .	6-2
------------------------	-----

## **Index**



---

# Preface

This instruction manual explains how to install, use, and maintain the NV3064 Router. Sections and topics included in the manual are the following:

- **Section 1: General Description**  
General information about the NV3064 Router and its uses.
- **Section 2: Installation**  
Installing the NV3064 Router and making connections.
- **Section 3: Operation**  
Procedures for using the NV3064 Router.
- **Section 4: Theory of Operation**  
Technical overview of the router and circuit boards.
- **Section 5: Maintenance**  
Maintenance, troubleshooting, and adjustment procedures.
- **Section 6: Notes**  
Late-breaking information about product.

## Quick Start

If you are setting up the NV3064 Router for the first time and wish to do so as quickly as possible, do the following:

1. Check Section 6 briefly for late-breaking changes or information.
2. See “Section 2: Installation” to install the NV3064 Router. Refer also to the *UniDiag Instruction Manual* for software configuration instructions.

## Important Safeguards and Notices

The information on the following pages provides important safety guidelines for both operators and service personnel. Specific warnings and cautions appear throughout the manual where they apply. Please read and follow this important information, especially those instructions related to the risk of electric shock or injury to persons.



**WARNING:** Any instructions in this manual that require opening the equipment cover or enclosure are for use by qualified service personnel only. To reduce the risk of electric shock, do not perform any service other than that contained in the operating instructions unless you are qualified to do so.

---

## Symbols and Their Meanings



The lightning flash with arrowhead symbol within an equilateral triangle alerts the user to the presence of dangerous voltages within the product's enclosure that may be of sufficient magnitude to constitute a risk of electric shock to persons.



The exclamation point within an equilateral triangle alerts the user to the presence of important operating and maintenance/service instructions.



The Ground symbol represents a protective grounding terminal. Such a terminal must be connected to earth ground prior to making any other connections to the equipment.



The fuse symbol indicates that the fuse referenced in the text must be replaced with one having the ratings indicated.



The presence of this symbol in or on NVISION equipment means that it has been designed, tested and certified as complying with applicable Underwriter's Laboratory (USA) regulations and recommendations.



The presence of this symbol in or on NVISION equipment means that it has been designed, tested and certified as essentially complying with all applicable European Union (CE) regulations and recommendations.

---

## Warnings

A warning indicates a possible hazard to personnel which may cause injury or death. Observe the following general warnings when using or working on this equipment.

- Heed all warnings on the unit and in the operating instructions.
- Do not use this equipment in or near water.
- This equipment is grounded through the grounding conductor of the power cord. To avoid electrical shock, plug the power cord into a properly wired receptacle before connecting the equipment inputs or outputs.
- Route power cords and other cables so they are not likely to be damaged.
- Disconnect power before cleaning the equipment. Do not use liquid or aerosol cleaners; use only a damp cloth.
- Dangerous voltages may exist at several points in this equipment. To avoid personal injury, do not touch exposed connections and components while power is on.
- Do not wear rings or wristwatches when troubleshooting high current circuits such as the power supplies.
- During installation, grasp the chassis of the equipment firmly and lift with your legs; do not bend over at the waist to lift heavy items. Moreover, do not rely on door handles or front panels to lift the equipment as they are not intended for this purpose.
- To avoid fire hazard, use only the specified fuse(s) with the correct type number, voltage and current ratings as referenced in the appropriate locations in the service instructions or on the equipment. Always refer fuse replacements to qualified service personnel.
- To avoid explosion, do not operate this equipment in an explosive atmosphere.
- Have qualified service personnel perform safety checks after any completed service.
- If equipped with redundant power supplies, the equipment has two power cords. To reduce the risk of electric shock, disconnect both power supply cords before servicing the unit.

## Cautions

A caution indicates a possible hazard to equipment that could result in equipment damage. Observe the following general cautions when operating or working on this equipment.

- When installing this equipment, do not attach the power cord to building surfaces.
- To prevent damage to equipment when replacing fuses, locate and correct the problem that caused the fuse to blow before re-applying power.
- Verify that all power supply lights are off before removing the power supply or servicing the equipment.
- Use only the specified replacement parts.
- Follow static precautions at all times when handling this equipment.
- This product should only be powered as described in the manual. To prevent equipment damage, select the proper line voltage at the AC input connector (if applicable) as described in the installation documentation.
- To prevent damage to the equipment, read the instructions in the equipment manual for proper input voltage range selection.
- To maximize protection against unwanted power loss, ensure that the power cords for redundant power supplies are plugged into separate branch circuits.

## North American Power Supply Cords

The power cords supplied with this equipment have a molded grounding plug (NEMA 5-15P) at one end and molded grounding receptacle (IEC 320-C13) at the other end. Conductors are CEE color-coded: Light blue (neutral), Brown (line) and Green or Green/Yellow (ground).

Operation of this equipment at voltages exceeding 130 VAC will require power supply cords which comply with NEMA configurations.

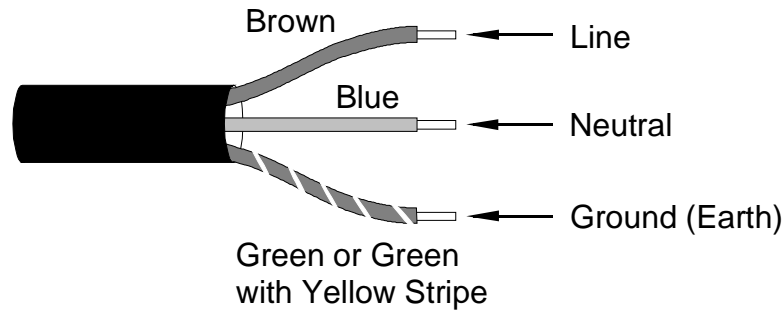

## International Power Supply Cords

The power cords supplied with this equipment have a molded grounding receptacle (IEC 320-C13) at one end and stripped conductors (50/5 mm) at the other end. Conductors are CEE color-coded: Light blue (neutral), Brown (line) and Green/Yellow (ground). Other IEC 320-C13 type power supply cords can be used if they comply with the safety regulations of the country in which they are installed.

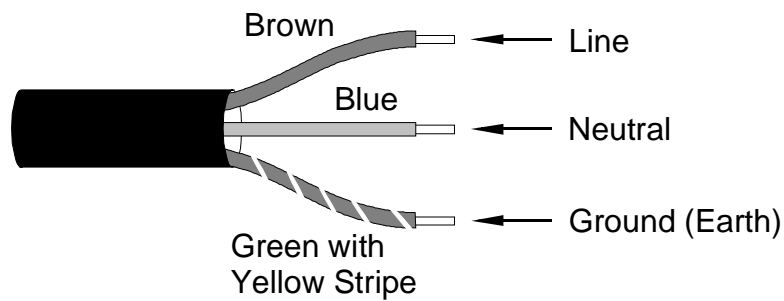

## FCC (USA) Compliance Statement

This equipment has been tested and found to comply with the limits for a Class A digital device, pursuant to Part 15 of the FCC Rules. These limits are designed to provide reasonable protection against harmful interference when the equipment is operated in a commercial environment.

This equipment generates, uses and can radiate radio frequency energy and, if not installed and used in accordance with the instruction manual, may cause harmful interference in which case the user will be required to correct the interference at their own expense.

## FCC Emission Limits

This device complies with Part 15 of the FCC rules. Operation is subject to the following two conditions:

1. This device may not cause harmful interference; and
2. This device must accept any interference received, including interference that may cause undesirable operation.

## European Community (CE) Declaration of Conformance

All of the equipment described in this manual has been designed to conform with the required safety and emissions standards of the European Community. Products tested and verified to meet these standards are marked as required by law with the CE mark (See *Symbols and Their Meanings* above.)

When shipped into member countries of the European Community, this equipment is accompanied by authentic copies of original Declarations of Conformance on file in NVISION corporate headquarters in Nevada City, California USA.

## **Year 2000 Warranty Statement**

NVISION warrants that all of its hardware, firmware and software products are not date-code sensitive and that their functionality will not be affected or altered in any way by a 21st century date code.

NVISION cannot warrant that the performance of NVISION products will not be impaired by interaction with third party equipment and software systems that may not be Y2K compliant.

NVISION internal operations, manufacturing services, accounting systems and engineering programs have been determined to be Y2K compliant and it is not anticipated that a 21st century date will affect the functionality of our business.

We are investigating our supply channels for components and services to ensure that they will not be affected by a 21st century date code, but we cannot warrant that our products or services will not be affected by external services beyond NVISION control.

### **Disclaimer**

NVISION disclaims all responsibility for product or service impairments that may arise due to interaction with third party product, equipment or services that are not Y2K compliant.

## Technical Support

NVISION has made every effort to ensure that the equipment and software you receive is in perfect working order and that it fits your needs. In the event that problems arise which you cannot resolve, or if there are any questions regarding this equipment or information about other products manufactured by NVISION, please contact your local representative or contact NVISION directly through one of the appropriate means listed below.

**Telephone:\*** Main Number - 1-530-265-1000  
Technical Support - 1-530-265-1059  
Sales - 1-800-719-1900/1-530-265-1000

**Facsimile:** Main Number - 1-530-265-1010  
Sales - 1-530-265-1021

**Email:** Technical Support - support@nvision1.com  
Sales - sales@nvision1.com

**Web Site:** <http://www.NVISION1.com>

**Mail:** NVISION, Inc.  
P.O. Box 1658  
Nevada City, CA 95959, USA

**Shipping:\*\*** NVISION, Inc.  
125 Crown Point Court  
Grass Valley, CA 95945, USA

\* Available from 8:00 a.m. to 5:00 p.m., Monday-Friday, Pacific Standard Time.

\*\* Material Return Authorization required for all returns.

# Section 1: General Description

This section introduces and provides general information and specifications for the NV3064 Router manufactured by NVISION, Inc. It includes:

- “Receiving Inspection” on page 1- 2
- “Unpacking Instructions” on page 1- 2
- “Product Overview” on page 1- 3
- “Features” on page 1- 4
- “Specifications” on page 1- 5

## Receiving Inspection

Inspect all containers for damage. If any is found, carefully inspect the contents for damage. If any equipment is damaged, notify the carrier immediately.

## Unpacking Instructions

Assuming your inspection showed no damage, carefully unpack all containers. Unwrap all boards and place them on a flat, level, static-free surface. Compare what was received against the packing slip. If any discrepancy is found or any products appear damaged, contact NVISION before proceeding.



**CAUTION: To prevent damage to electronic components and connectors, follow these precautions: DO NOT DROP OR BANG BOARDS, DO NOT STACK BOARDS, AND DO NOT FORCE BOARDS INTO THE FRAME.**

**Always inspect card connectors for bent pins prior to inserting them into the frame. When properly aligned and inserted, boards seat easily in the motherboard connectors with only a gentle push. If you experience difficulty inserting a board, stop and call the factory for help before any damage occurs.**

---

## Product Overview

The NV3064 Router (Figure 1-1) includes the following main components:

- One 6 RU Electronics Frame with Phoenix or BNC Connectors.
- One 64 x 64 Crosspoint switching card.
- One or two I/O Modules for 32 x 32 or 64 x 64 Inputs/Outputs.
- One Control card with slot for a second reserve card.
- One Power Supply card with slot for a second redundant card.
- North American or International power cable.



Figure 1-1. NV3064 Router

## Features

The NV3064 series of routers provides intermediate sized routing capacity for asynchronous or synchronous AES signals or time code. The following features are available with NV3064 routers:

- Three models available:  
NV3064A for asynchronous AES audio  
NV3064SA for synchronous AES audio  
NV3064TC for timecode
- Single I/O card with 32 x 32 inputs and outputs. Easy expansion to 64 x 64 by simply plugging in a second I/O card.
- Accepts one I/O card for 32 x 32 AES and a second for 32 x 32 time code, providing both AES and time code routing.
- BNC or Phoenix terminal block I/O connectors can be specified.
- All AES data rates supported at the same time in the same frame (asynchronously).
- Configuration is done in software using the UniDiag PC program.
- UniDiag includes many useful diagnostic and control features.
- Industry standard RS-422 control can be slaved to NVISION's ENVY routing control system, existing OEM router control systems, or operated from NVISION NV9301 X-Y or NV9302 Source Select control panels.
- NV3064SA features true synchronous switching with no pops or glitches.
- Redundant Power Supply option.

## Specifications

Table 1-1 presents specifications for the NV3064 Router.

**Table 1-1. NV3064 Router Specifications**

<b>Electrical</b>	
AC Line Input:	90 - 135 or 180 - 270 VAC, 50 - 60 Hz, user selectable.
AC Line Fusing:	250 Volts, 1.6 Amps, 5 x 20 mm, Slow Blow.
Power Consumption:	45 Watts, nominal (varies with versions and options).
Safety Certifications:	Underwriter's Laboratory approved, Control No. 9K50.
<b>AES Signal Inputs &amp; Outputs (3064A/SA)</b>	
Number of Inputs/Outputs:	32 x 32 or 64 x 64. NV3064SA inputs and outputs are frequency-locked to the reference input.
Interface Standards:	AES/EBU 110 ohm twisted pair with Phoenix pluggable screw-type terminal blocks or 75 ohm 1 volt coaxial BNC connectors.
Input Impedance:	110 ohms, 75 ohms, or high impedance, selectable.
Output Impedance:	110 ohms or 75 ohms, backplane option.
Data Rates:	28 kHz to 54 kHz audio sample rate (async), 48 kHz (sync).
<b>Video Reference Input</b>	
Video Signal:	1 Vpp composite NTSC or PAL.
Input Impedance:	High impedance or 75 ohms external.
<b>Control &amp; Diagnostic Ports</b>	
Control Port Interface:	One 9-pin D Control Port, EIA RS-422 SMPTE 207M twisted pair. DCE Controlled Device with loop-thru.
Diagnostic Port Interface:	One 9-pin D EIA RS-232 Diagnostic port on the back of the frame. Second Diagnostic port on the front of the Control Card.
Ethernet and Node Bus:	SMS7000 Ethernet and Node Bus BNC connections.

**Table 1-1. NV3064 Router Specifications (Continued)**

<b>Time Code Inputs &amp; Outputs (3064TC)</b>	
Number of Inputs/Outputs:	32 x 32 or 64 x 64.
Interface:	SMPTE 12M-1986 Time Code, twisted pair.
Input Impedance:	200 mV to 10 Vpp/600 ohms or high impedance, selectable.
Output Impedance:	2.5 Vpp/50 ohms.
Connectors:	Balanced, plug-in terminal block Phoenix connectors.
Performance:	1/30th to 100 times play speed.
<b>Control Systems available</b>	<p>NVISION ENVY Router Control System, including various control panel options.</p> <p>NV9301 X-Y control panel or NV9302 Source Selector Control Panel.</p> <p>A variety of OEM audio/video router control systems.</p> <p>Connect via the industry-standard RS-422 Serial Control Port or SMS7000 Ethernet and Node Bus.</p>
<b>Mechanical</b>	
Height (approx):	6 rack units (10.5 inches/267 mm).
Width (approx):	19 inches/483 mm.
Depth (approx):	16 inches/406 mm.
Weight (approx):	43 pounds/95 kilograms.
<b>Environmental</b>	
Operating Temperature:	0 - 40 degrees Celsius, ambient.
Relative Humidity:	0 - 90% non-condensing.

Specifications are subject to change without notice or obligation.

## Section 2: Installation

This section explains how to install and configure the NV3064 Router. The following topics are covered in this sections:

- **“Installing the NV3064 Router” on page 2-2**  
How to install the NV3064 Router in a rack.
- **“Required Jumper Settings” on page 2-5**  
Setting card jumpers for correct line voltage and AES termination.
- **“Connecting Cables to the NV3064 Router” on page 2-10**  
Connecting cables and power to the NV3064 Router.
- **“Configuring the NV3064 Router for Use” on page 2-15**  
Using the UniDiag software to partition the router.

## Installing the NV3064 Router

The NV3064 Router installs in a standard EIA 19-inch (483 mm) equipment rack, where it occupies 6 rack units (10.5 inches/267 mm) of vertical space.

### Tools and Materials Required

- Wrench, 2 mm hexagonal (Allen)
- Rack screws, quantity of 8
- Screwdriver for rack screws

### Installing the Frame

See Figure 2-1 and follow these steps to install the frame in the rack:

1. Use the 2 mm hex wrench to remove the six screws holding the front doors onto the frame and remove the doors.
2. Have a helper lift the frame into the rack and support it.
3. Insert rack screws through the eight holes in the frame's rack ears and tighten the screws down.
4. Re-install the frame front doors.

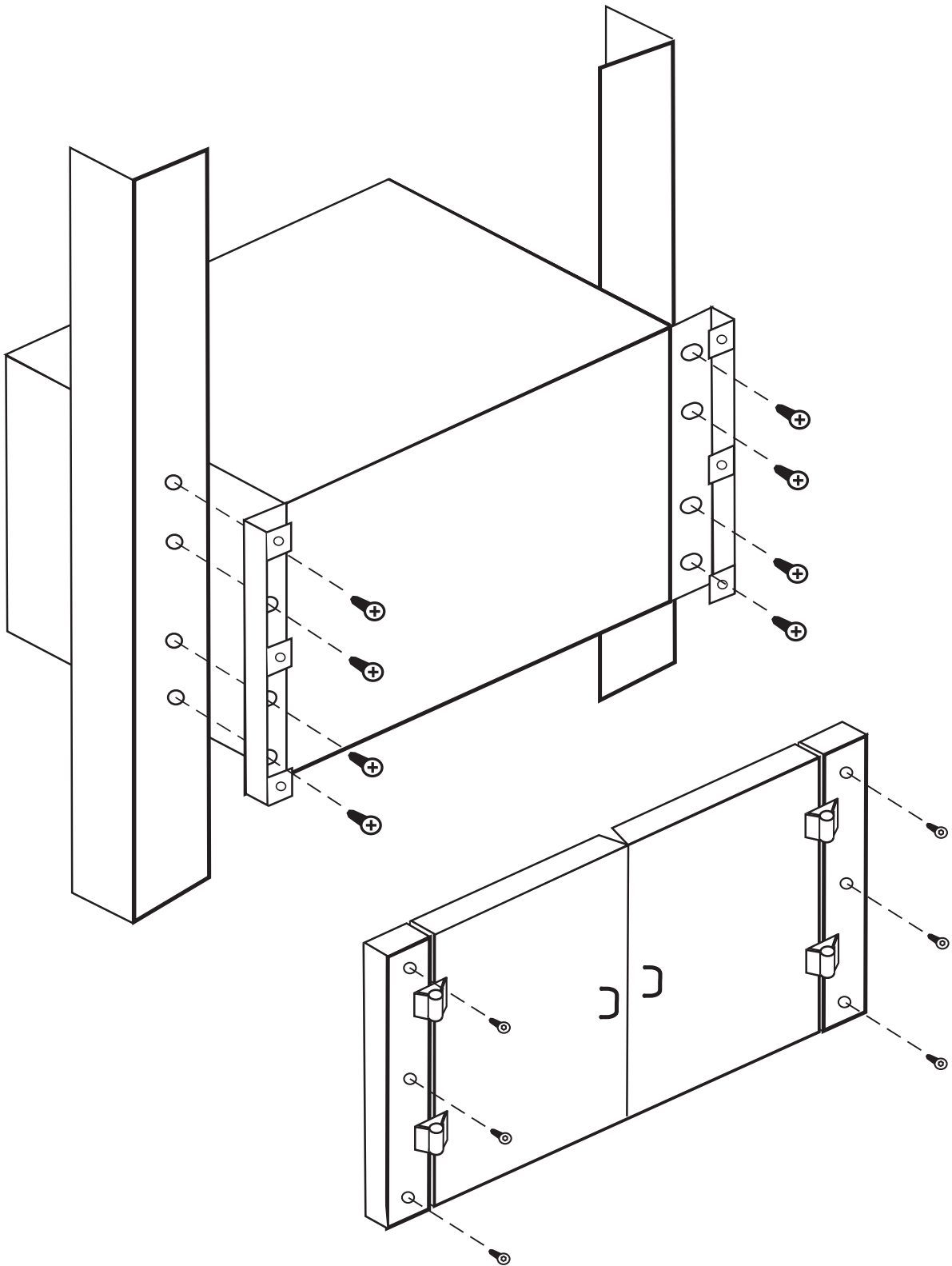

Figure 2-1. Electronics Frame Installation

## Inserting Cards into the Frame

The router is shipped with cards in the correct positions in the frame. In case the cards have been removed, you can use Figure 2-2 below to re-install the cards. The front of the frame is also marked on the left side of each slot with a legend showing which cards go into which slots.

1. To install a card, start the edges of the card into the slots along each side of the frame.
2. Make sure the ejector levers on the front of the card are sticking out, approximately perpendicular to the front of the frame.
3. Slide the card into the frame until it seats in the rear connectors.
4. Press the ejectors until they lock into position flat against the front of the card and parallel to the front of the frame.

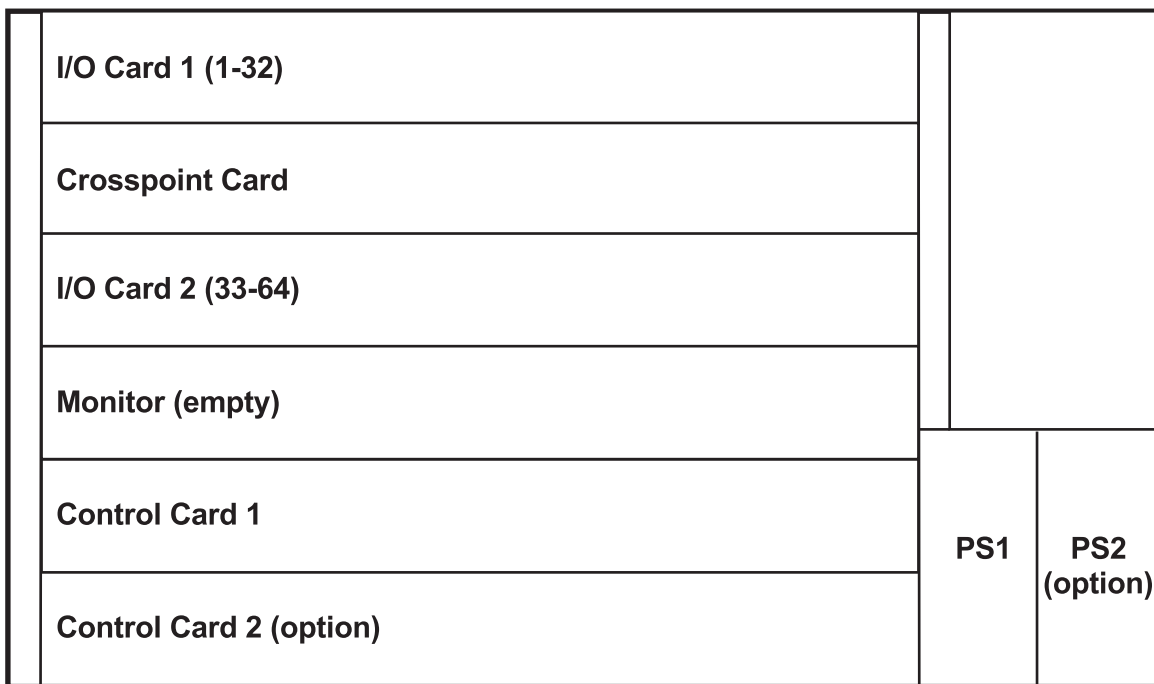

Figure 2-2. Card Locations in the Router Frame

## Required Jumper Settings

Configuring the NV3064 Router requires setting a few jumpers before you apply power or make connections.

### PS2001 Power Supply Card Line Voltage Jumper

The Power Supply Card(s) have a jumper for setting the AC Line input voltage. See Figure 2-3 and set the jumper as follows:

1. Set **VSEL** jumper **J1** on each Power Supply Card for **115 VAC** or **230 VAC**.



**CAUTION:** To prevent damage to the Power Supply Card, it is crucial that you set VSEL jumper J1 to the correct AC line voltage available in your facility before applying power.

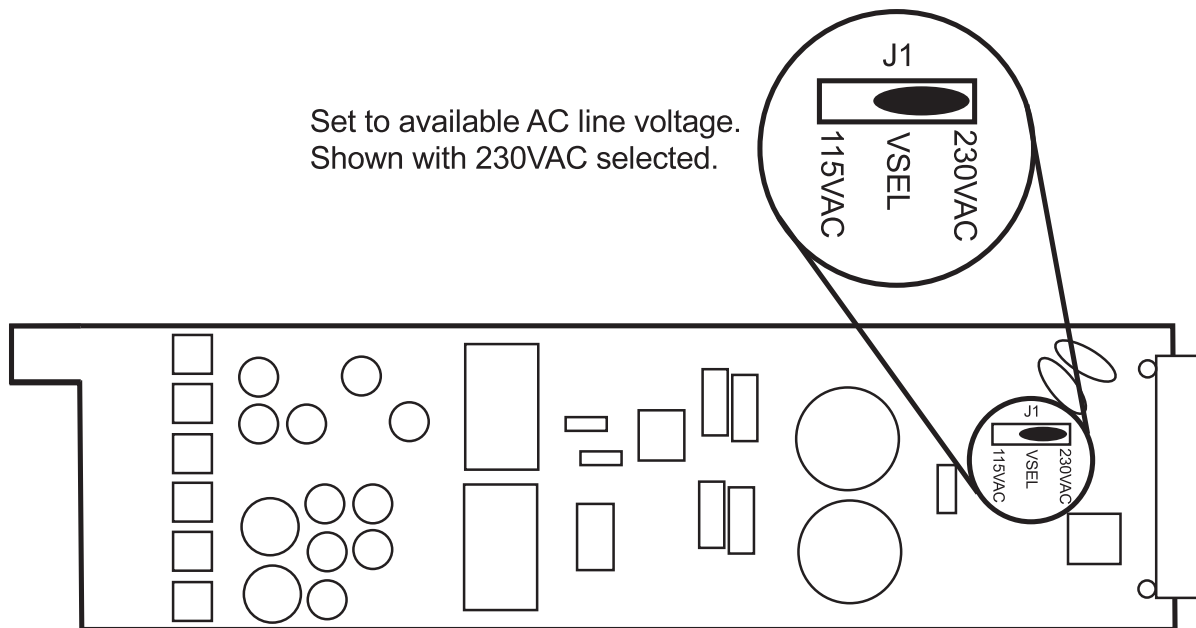
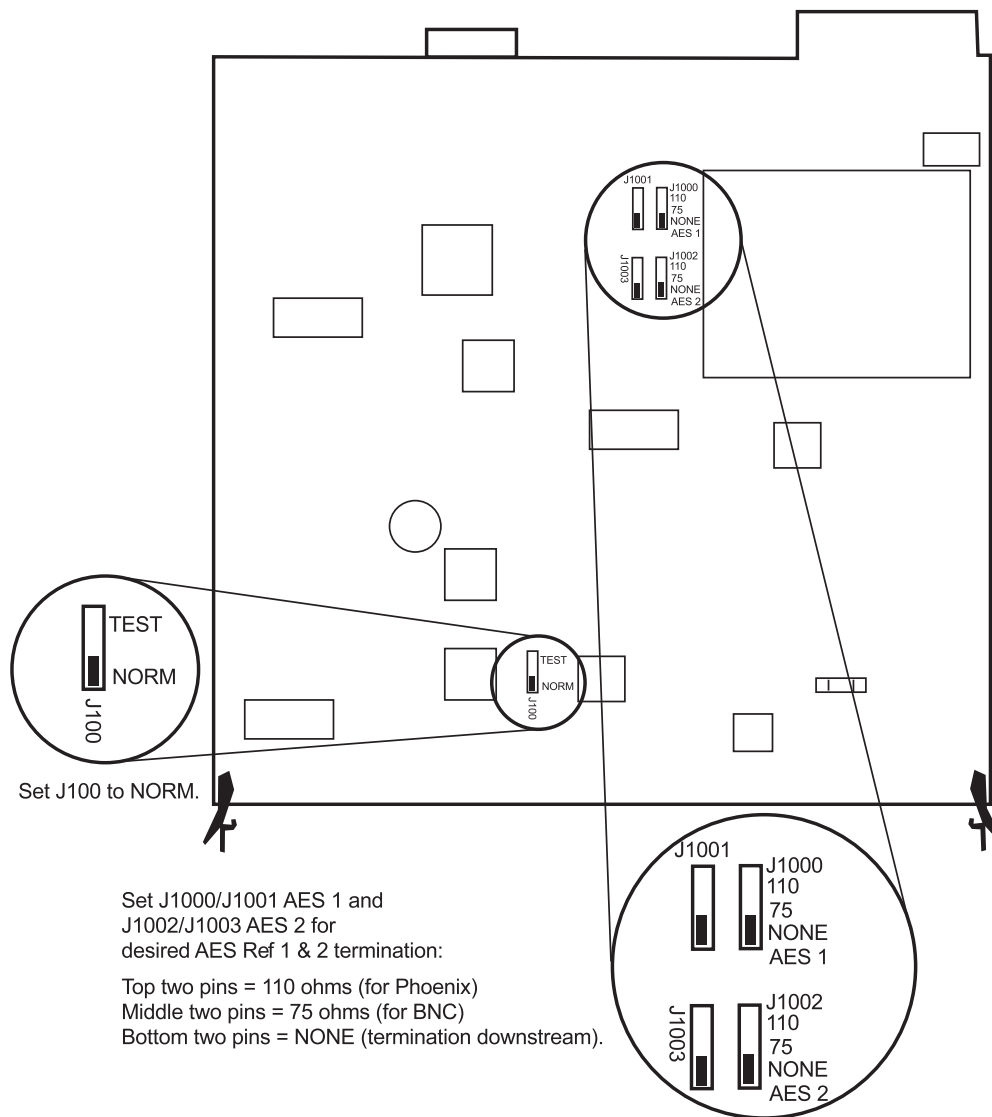

Figure 2-3. Power Supply Voltage Select Jumper Setting

## Universal Control Card AES Ref Termination Jumper

The EM0134 Universal Control Card contains a Test/Normal jumper and four jumpers for setting the termination impedance of the two AES Reference inputs. See Figure 2-4 and set the jumpers as follows:

1. Set **TEST/NORM** jumper **J100** to **NORM** for regular operation.
2. Set **AES 1** jumpers **J1000** and **J1001** to **110** ohms (Phoenix), **75** ohms (BNC), or **NONE** (downstream termination). Both must be set to the same selection.
3. Set **AES 2** jumpers **J1002** and **J1003** to **110** ohms (Phoenix), **75** ohms (BNC), or **NONE** (downstream termination). Both must be set to the same selection.



**Figure 2-4. Universal Control Card Jumper Settings**

## Asynchronous I/O Card Jumpers

The AES Asynchronous/Timecode I/O card includes 32 jumpers for setting the termination of the AES or time code inputs. See Figure 2-5 and set the jumpers as follows:

Pins	AES Setting	Time Code Setting	Purpose
1 - 2	110 ohms	High Impedance	Use this for AES with Phoenix connectors.
2 - 3	75 ohms	600 ohms	Use this for AES with BNC connectors.
Off	High Impedance		Use this when terminating downstream.

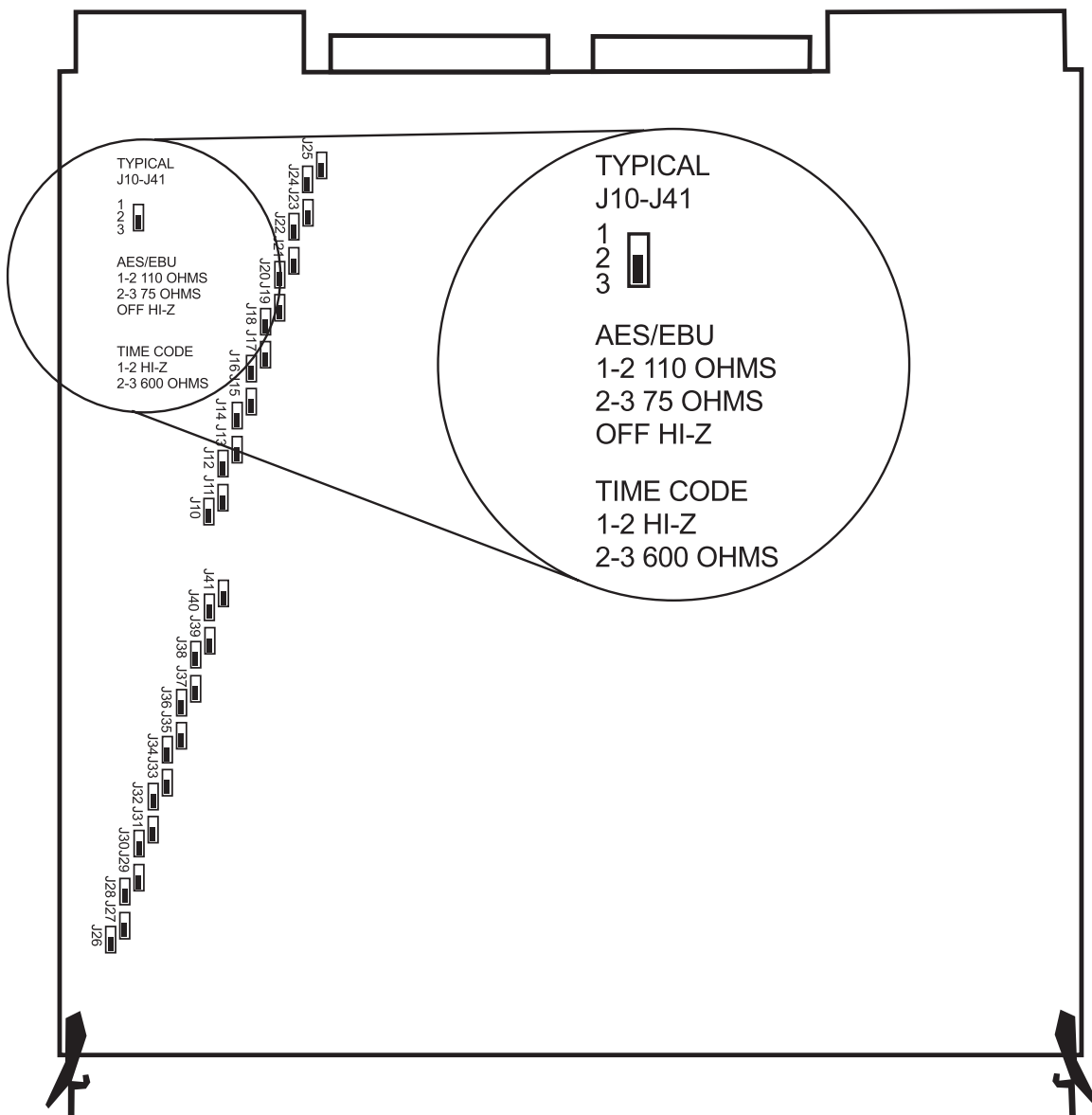

Figure 2-5. Asynchronous I/O Card Jumpers

## AES Synchronous I/O Card Jumpers

The AES Synchronous I/O card includes many jumpers for setting the termination of the AES or time code inputs. See Figure 2-6 and set the jumpers as follows:

<b>Pins</b>	<b>AES Setting</b>	<b>Time Code Setting</b>	<b>Purpose</b>
1 - 2	110 ohms	High Impedance	Use this for AES with Phoenix connectors.
2 - 3	75 ohms	600 ohms	Use this for AES with BNC connectors.
Off	High Impedance		Use this when terminating downstream.

Another set of jumpers on this module associated with ASICS U700 - U703 sets whether the CS data is passed through or replaced by the ASIC's internal generic CS data. The default is pass-through: jumper pins 1 and 2.

<b>Jumper Setting</b>	<b>Purpose</b>
Pins 1 - 2 (typical)	Pass Channel Status data through unchanged.
Pins 2 - 3	Replace Channel Status data with generic CS data.

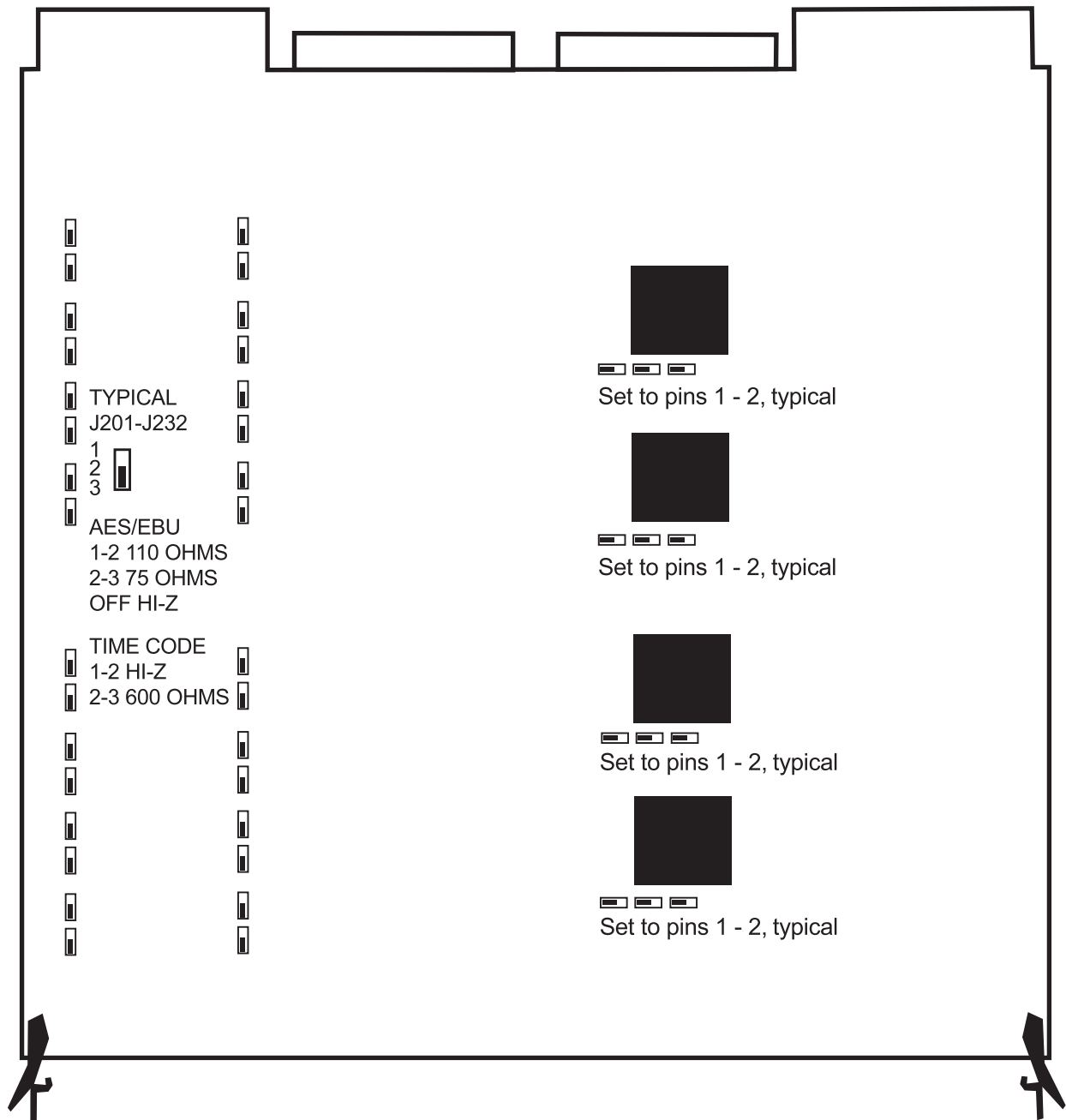

Figure 2-6. Synchronous I/O Card Jumpers

## Connecting Cables to the NV3064 Router

The router backplane includes either BNC or Phoenix terminal block connectors for signal input and output connections, depending on which backplane was ordered from the factory. Signal, control, and power connections to the router backplane are explained in Figure 2-7 and Table 2-1. Make connections as indicated.

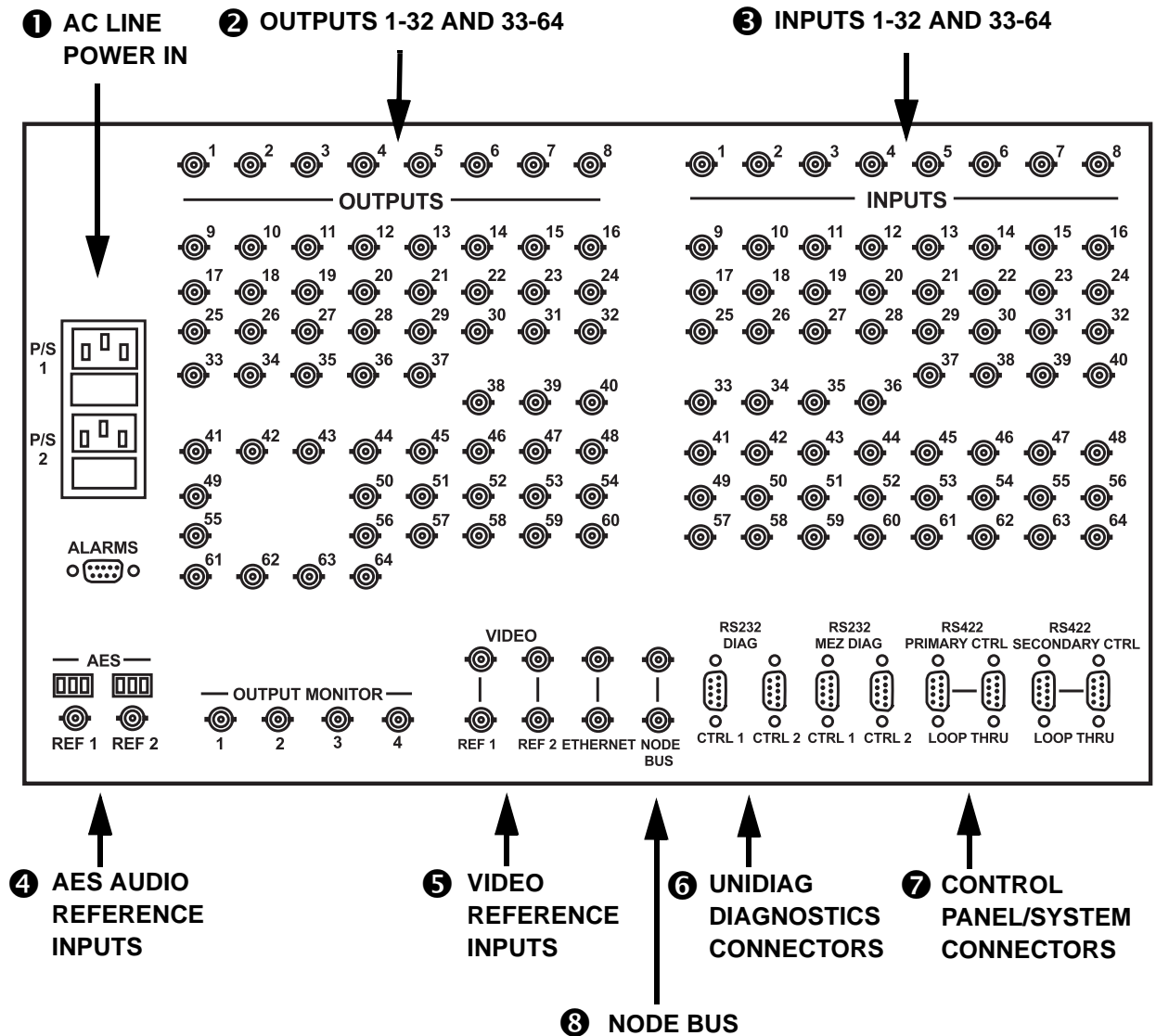

Figure 2-7. NV3064 Router Cable Connections

The following table is keyed to Figure 2-7 and explains the connections to the NV3064 Router backplane. Connectors not described are unused.

**Table 2-1. Cable Connections**

No.	Connector and Function
①	<b>AC Line Power In</b> - For AC power. See the connection instructions on the following page before applying power.
②	<b>Outputs, AES or Timecode</b> - These are the router signal outputs. Use Outputs 1-32 for a 32 x 32 system.
③	<b>Inputs, AES or Timecode</b> - These are the router signal Inputs. Use Inputs 1-32 for a 32 x 32 system.
④	<b>AES Ref In 1 &amp; 2</b> - Connect stable sources of AES audio to these inputs to serve as the reference to which the outputs will be phase-aligned (synchronous systems only).
⑤	<b>Video Ref In</b> - Connect stable sources of NTSC or PAL video to these inputs to serve as references for vertical interval switching of audio (synchronous systems only).
⑥	<b>UniDiag Control Connectors</b> - RS-232 connectors used for long-term connection of a serial cable to a PC serial port for UniDiag control of the router. CTRL 1 is associated with Control Card 1, and CTRL 2 is associated with Control Card 2 (if any). See the following connector pin-outs.
⑦	<b>Control Connectors</b> - RS-422 connectors used for connecting NVISION control panels or other controllers to the router. See the following connector pin-outs.
⑧	<b>Node Bus &amp; Ethernet</b> - Used with SMS7000 control systems.

## RS-422 and RS-232 Connector Pin-Outs

Figure 2-8 shows how to make connections to the female 9-pin D RS-422 and RS-232 frame connectors. The mating connector is a male 9-pin D.

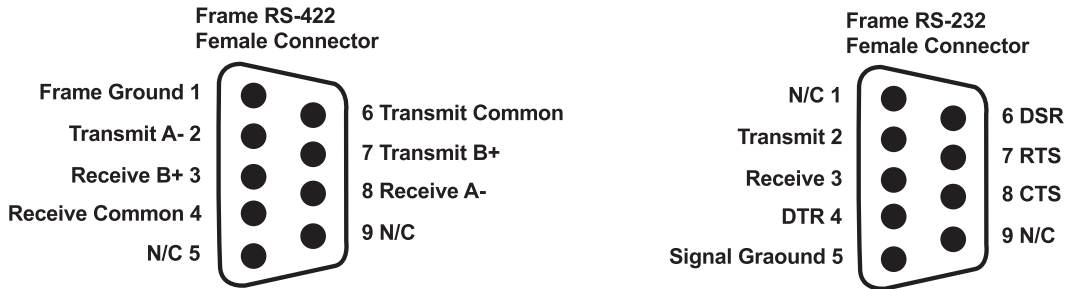

Figure 2-8. RS-422 and RS-232 Connector Pin-Outs

## Connecting to Phoenix Connectors

When equipped with Phoenix connectors on the backplane, the NV3064 Router can receive and transmit AES audio as balanced signals over shielded twisted pairs, or time code as either balanced or unbalanced signals. The input and output circuitry automatically adjusts to balanced or unbalanced connections. Note that you can also use a single-ended connection for AES audio, but to do so you will need a balun (impedance matching transformer).

Figure 2-9 shows examples of balanced AES and single-ended time code connections. For AES audio, use a good quality shielded twisted pair cable, such as Belden 9180. For time code, you can use less expensive cable or coax, including analog audio cable.

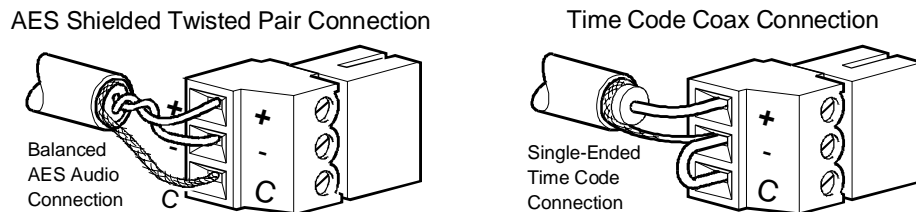

Figure 2-9. Connections to Phoenix Connectors

## AC Power Connection

After connections have been made and the Power Supply Card(s) have been set for the correct AC line voltage, connect AC line power to the back of the frame using the supplied power cable.



**CAUTION:** To prevent damage to the Power Supply Card, it is crucial that you set VSEL jumper J1 on that card to the correct AC line voltage available in your facility before applying power.

As shown in 2-10, connect only one power cord if only one power supply card is installed. The single cord should be connected to the upper connector if the power supply card is in slot PS1 and to the lower connector if the card is in PS2. If two power supply cards are installed (redundant supplies), connect power cords to both connectors.



**WARNING:** The NV3064 Router does not have a power switch. Power is applied to the router as soon as the power cords are connected. The power cords are the only means of disconnecting AC power from the mains. Make sure you locate the router where the AC power outlet is nearby and easily accessible so you can quickly disconnect power in an emergency.

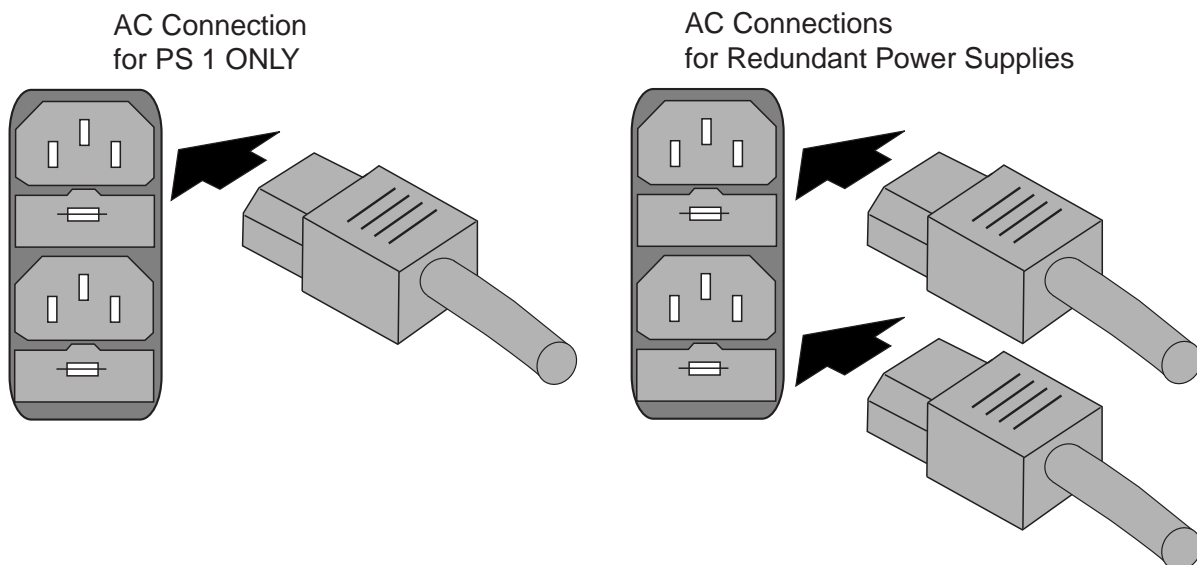

Figure 2-10. AC Power Connections

## Fuses

When power is applied, the power LEDs on the front of the frame modules light up and the router is ready for operation. Verify that the power LEDs on all modules are lit. If any LEDs are not lit, verify the continuity of on-board fuses (if any) listed in Table 2-2.

If the entire system fails to power up, remove the power cable and open the fuse compartment in the AC power connector below the three connector prongs (Figure 2-11). Verify the continuity of the fuse.

**Table 2-2. AC Line and On-Board Fuses**

Location	Fuse Value
Rear AC Line Connector(s)	5 X 20 mm, 1.6A slo-blow, 250V
Control Card, F1100	5 X 20 mm, 1.6A slo-blow, 250V
I/O Card(s) F1 and F2	5 X 20 mm, 1.6A slo-blow, 250V

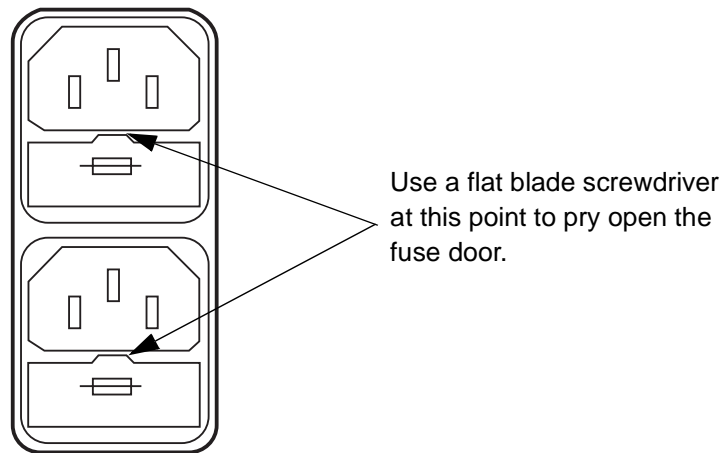

**Figure 2-11. Checking AC Line Fuse(s)**

## **Configuring the NV3064 Router for Use**

Partitioning the router into levels and assigning sources and destinations to the levels is done using the UniDiag software supplied with the router. The UniDiag executable runs on a PC under Windows\* 95 or NT.

UniDiag communicates through a PC serial port to the router via the serial port on the front of the Control Card or the Diagnostic connector on the back of the frame. You will need a standard straight-through RS-232 serial cable to connect from the PC to the router.

See the UniDiag Instruction Manual for details about connecting the PC to the router and for instructions about operating UniDiag.



## **Section 3: Operation**

This section of the manual refers to operating information found in other manuals, since the operation of the router depends on the control system used. The following topics are covered:

- “Introduction” on page 3-2

## **Introduction**

Operation of the NV3064 Router is straightforward but varies with the control system you choose. Products that may be used to control the NV3064 Router include the NV9301 X-Y panel, the NV9302 Source Select panel, the Envy router control system, third party router control systems, and even UniDiag, although UniDiag is meant for configuration and diagnostic control use only.

Depending on the control system, the NV3064 Router is capable of being partitioned into multiple physical levels. Synchronous digital audio routers can perform noiseless switching within the video vertical interval.

For detailed operating instructions, see the manual for the control system you are using with the router.

## **Section 4: Theory of Operation**

This section gives an overview of the router circuitry and internal operation. Because assemblies are replaced as units and no circuit-level repairs can be done, descriptions are confined to the block diagram level.

Topics included in this section are the following:

- **“NV3064 Router System Overview” on page 4-2**
- **“I/O Cards” on page 4-4**
- **“Control Card” on page 4-4**
- **“Crosspoint Matrix Card” on page 4-5**
- **“Power Supply” on page 4-6**

## NV3064 Router System Overview

Figure 4-1 shows a block diagram of the NV3064 Router. The Input and Output circuits are located on the I/O cards, the Matrix Control block corresponds to the Universal Control card, and the Crosspoint Matrix is located on the Crosspoint card.

Inputs enter the backplane connectors and are distributed via the motherboard to the I/O cards. The signals are buffered in all router types and phase aligned to the AES reference in synchronous routers only.

The signals are then applied to the crosspoint matrix. Switching in the crosspoint matrix occurs under the direction of the Control card, which also processes the reference signals. In synchronous routers the crosspoint switching is timed to occur during video vertical interval and is gated to occur at the sample frame boundary.

The output signals from the crosspoint matrix return to the I/O cards where they are processed differently for output, depending on whether the router is synchronous, asynchronous or time code. Asynchronous routers simply apply the signals to the output drivers. Synchronous routers process the output to provide output framing and insertion of channel status data. Time code routers analyze the output signal for frequency content and use the information to control output signal rise time. This process generates clean trapezoidal waveforms at a very wide range of shuttle speeds.

For all router types, output drivers on the I/O cards drive the audio or time code signals onto the rear connectors via the motherboard.

See the following pages for more detailed information about each circuit board.

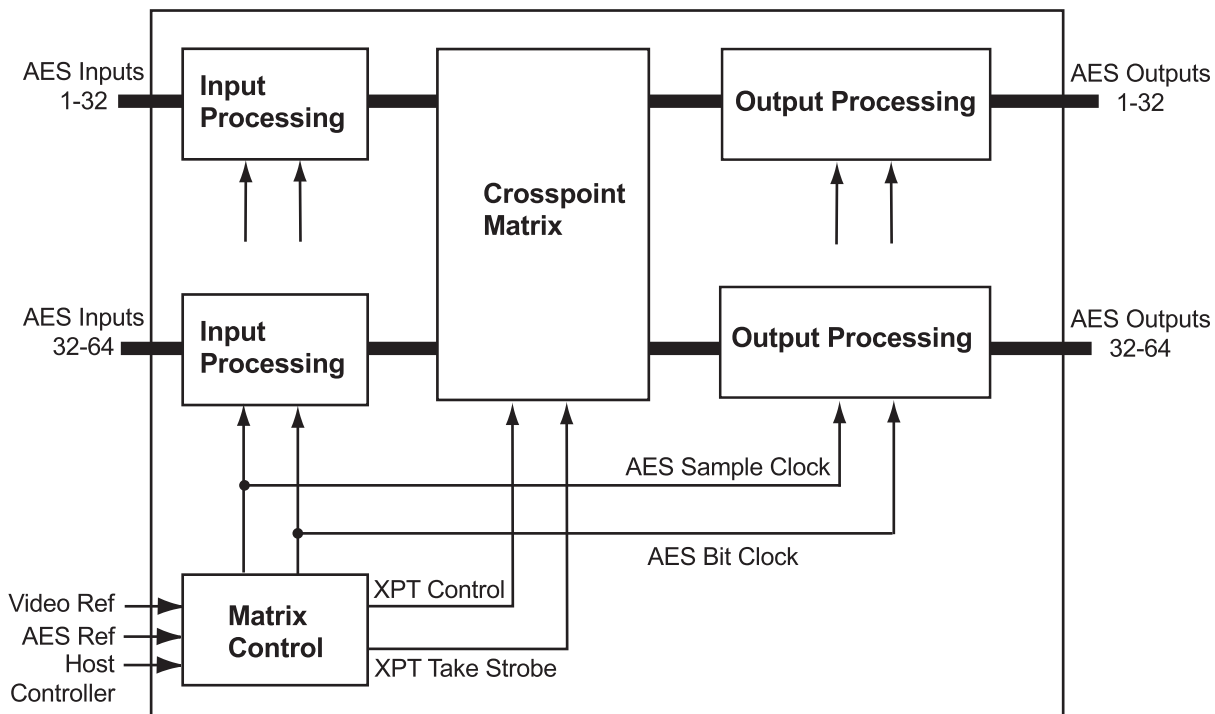

Figure 4-1. System Block Diagram.

## I/O Cards

The AES digital audio or timecode inputs enter the router backplane via the BNC or Phoenix connectors. These signals are distributed by the backplane and motherboard to the Input/Output (I/O) card(s). The frame can hold up to two I/O cards, one for each group of 32 inputs and outputs. The types of I/O cards are asynchronous, synchronous, and time code.

The I/O cards contain receiver circuits that buffer the incoming time code signals or serial audio data streams and recover the embedded clocks and digital audio data. In the asynchronous and time code systems, the signals are passed via the motherboard to the Crosspoint Matrix card. In the synchronous systems, the I/O cards first retime and rephase the serial data streams to match the phase and timing of the AES Reference Input coming from the Control card.

Signal outputs from the Crosspoint card reenter the I/O cards via the motherboard. In synchronous routers an ASIC (Application Specific IC) inserts channel status and signal presence data on the data streams, and in all routers output drivers send the signals to the signal output connectors on the backplane. For synchronous routers, clocking of the output circuits is provided by reference clocks from the Control card.

## Control Card

One or two Universal Control cards can be installed in the router. A second card is not required but provides a reserve in case the first one must be taken offline.

The Control module contains microprocessors and memory that store and act on control information from the external control system or UniDiag. Commands from the control system enter via one of the serial ports and are interpreted by the microprocessors into commands that are sent to the Crosspoint Matrix card via the motherboard to cause crosspoint switching. The crosspoint map, scramble map, and other current configuration data is maintained in RAM and updated by the microprocessors as changes occur. The microprocessors also monitor the router system and maintain information in memory about which cards are installed and their current status. A memory backup capacitor maintains data in RAM for several days if power is turned off or the module is removed to ensure that the router can return to its previous state after a power outage.

Three socketed boot PROMs store boot up programs for the microprocessors, and three socketed flash EPROMs store downloadable control system protocols. The socketed chips can be physically replaced or

the flash chips can be reprogrammed using UniDiag. This makes updating or changing the control system protocol a quick and simple process.

Also included on the Control card is the processing circuitry for the AES Reference (synchronous systems only) and Video Reference inputs. A timing ASIC accepts the AES sync 1 and 2 inputs and produces an AES sample clock and AES bit clock used on the I/O cards to phase align the AES audio inputs. A similar ASIC receives the Video Reference Sync Input and uses it to create a vertical interval take strobe that switches the crosspoint within the video vertical blanking interval and at the AES frame boundary in synchronous AES routers.

Interface circuitry on the Control module connects to the various serial data ports on the backplane and interfaces those data ports to the microprocessors. An SMS7000 Mezzanine provides a special control interface to the GSC Node Bus required for SMS7000 control systems. Systems purchased for other control systems contain an unstuffed mezzanine.

Power and signal presence LEDs on the front of the card indicate when power and reference input signals are present.

## **Crosspoint Matrix Card**

Up to 64 digital audio or timecode input signals from the I/O cards enter the Crosspoint Matrix card via the motherboard. The data is buffered and high frequency noise filtered before being applied to a proprietary 64 x 64 crosspoint chip. The crosspoint chip, which is clocked by a vertical interval strobe, handles all crosspoint switching in the router. Outputs of the crosspoint chip are buffered by line drivers that power the signals onto the I/O modules.

Control of crosspoint switching is provided by the Universal Control module, which processes control input selections from the user to produce control data on two data buses that feed the Crosspoint Matrix card. A register bus addresses specific crosspoint outputs, and a data bus holds the address of the input to which the selected output will connect. A crosspoint strobe from the Control card clocks the data into the data registers on the Crosspoint Matrix card that in turn load the data into the crosspoint switching IC.

## Power Supply

Power regulation in the NV3064 Router takes place in two stages. The first stage consists of the main power supply cards, which provide AC to DC power regulation. The DC outputs of the power supply cards are distributed through the motherboard to each active board in the frame. The second power regulation stage consists of on-board linear or switching regulators on each card in the frame. This arrangement ensures consistent, reliable power levels on each board. Schottkey diodes on each card assure proper load sharing between main and redundant supplies.

The UL-listed PS2001 power supply cards accept a nominal input voltage of 115 VAC or 230 VAC and produce  $\pm 7$  and  $\pm 17$  VDC outputs used to power the cards in the electronics frame. Actual input AC can vary between 88 - 135 VAC and 210 - 270 VAC, 47 - 63 Hz. Selection of the 115 or 230 input voltage is made by positioning jumper J1, which is located near the connector at the back of the board.

AC power enters the power supply cards through the supplied AC power cords connected to the power mains and the power input connectors on the back of the frame. The power connectors include a 1.6 ampere fuse to protect the equipment against shorts and RFI/EMI filters to attenuate power line noise and interference. The motherboard distributes the AC power to the power supply cards.

On the power supply cards the AC input is rectified by a full bridge diode, chopped by switching FETs into a high voltage 40 kHz square wave, and fed to a step-down transformer, secondary rectifiers, and LC filters. These circuits produce secondary DC power outputs of approximately  $\pm 17$  VDC and  $\pm 7$  VDC. (Note that voltages can be much higher when the router does not contain any active modules.) A pulse width modulation (PWM) submodule regulates the secondary outputs by controlling the pulse width produced by the switching FETs to keep the DC output voltage stable.

The power supplies are individually self-limiting, shutting down completely in the event of an excessive load. Operation resumes immediately when the overload is corrected. In addition, to protect against electric shock, the power supply boards automatically bleed power from the input capacitors when the board is removed from the frame. This removes dangerous voltages from the supply board when it is removed from the frame.



**Warning: To prevent electric shock, never power the board from a bench supply. The protective power bleed circuit will not function as it does when the board is plugged into the frame.**

---

## Section 5: Maintenance

This section describes maintenance, troubleshooting, and parts replacement procedures for the NV3064 Router.



**WARNING: Any instructions in this manual that require opening the equipment cover or enclosure are for use by qualified service personnel only. To reduce the risk of electric shock, do not perform any servicing other than that contained in the operating instructions unless you are qualified to do so.**

---

The following topics are presented in this section:

- “Routine Maintenance” on page 5-2
- “Troubleshooting and Repair” on page 5-6
- “Ordering Replacement Assemblies” on page 5-8

## Routine Maintenance

In normal operation the NV3064 Router requires no periodic maintenance other than a routine visual inspection. To help operators locate potential problems, LEDs on the front panels or near the front of PC boards indicate power, signal presence, and health. It's a wise practice to check the LEDs periodically to ensure that the system is healthy.

Indicators and test points for the various cards in the NV3064 Router are presented on the following pages.

## Universal Control Module

The Universal Control module front panel is shown in Figure 5-1. The three health indicator LED colors have the following meanings:

- RED**                      Problem or fault indication
- GREEN**                    Healthy or OK indication
- YELLOW**                   Indicates the module is the active primary module and not in standby or offline mode.

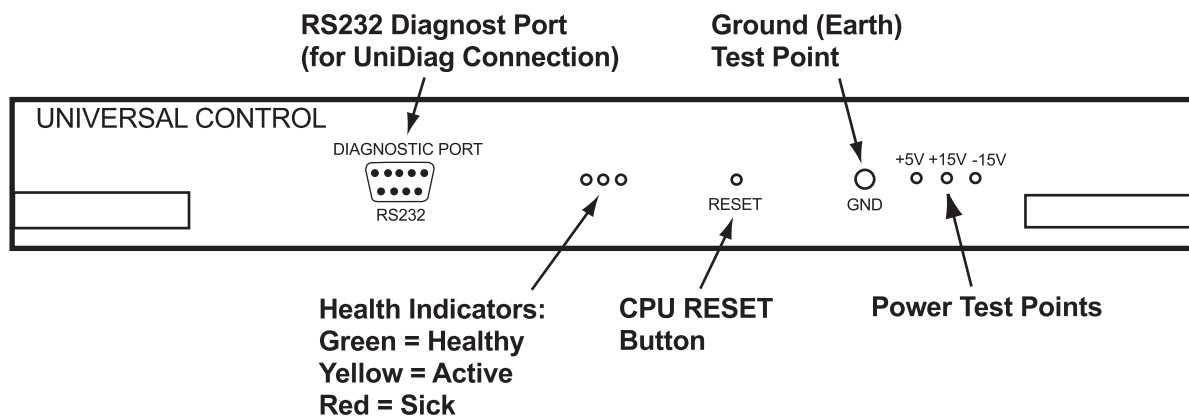

Figure 5-1. Universal Control Module Front Panel

## I/O Module

A synchronous AES I/O module front panel is shown in Figure 5-2. The module includes multiple power test points and indicators.

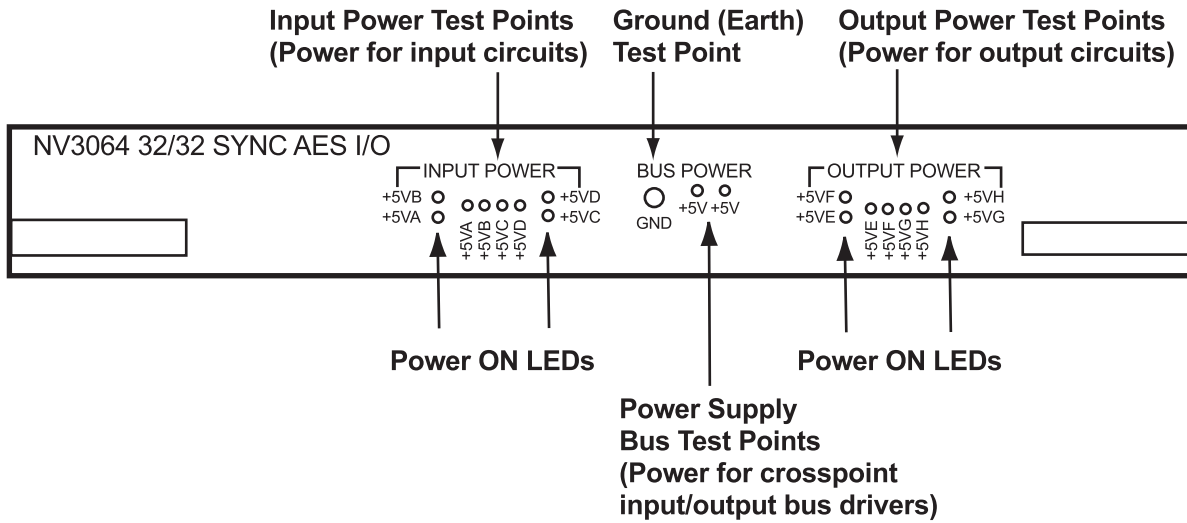

Figure 5-2. Synchronous I/O Module Front Panel

## Crosspoint Matrix Module

Figure 5-3 shows the front panel of the Crosspoint module.

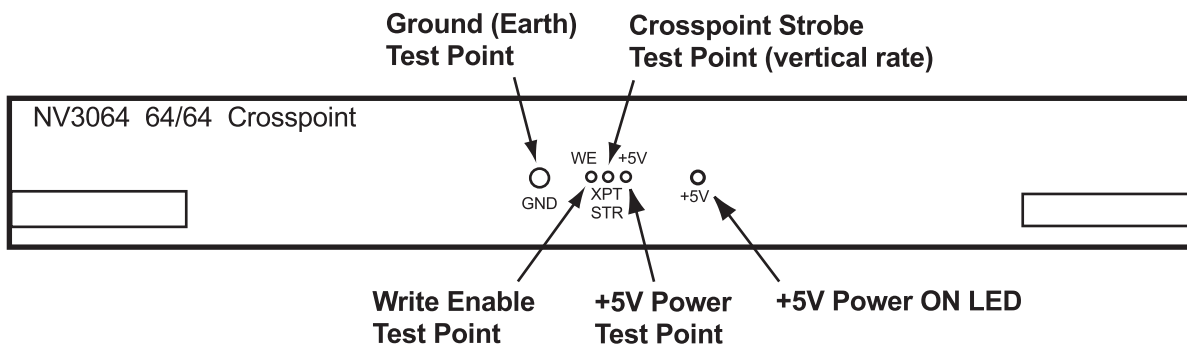

Figure 5-3. Crosspoint Module Front Panel

## Power Supply Module

Figure 5-4 shows the front panel of the PS2001 Power Supply module.

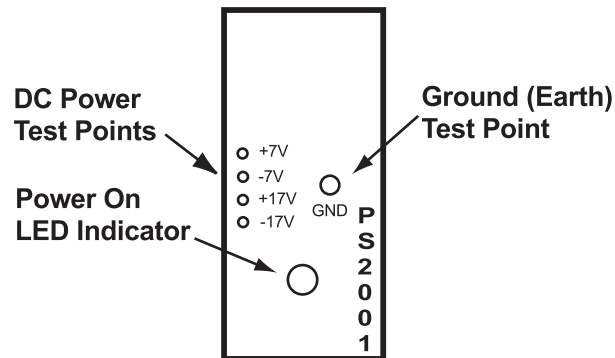

Figure 5-4. Power Supply Module Front Panel

## Fuses

Fuses are included in the rear power connectors and on certain modules. The locations and values of fuses are listed in Table 5-1 below. If a fuse blows, check the board or system for shorts that could have caused the fuse to blow. If no problems are found, replace the fuse but watch the system closely to make sure there are no shorts. If fuses blow repeatedly, a serious problem is likely to exist and power should be disconnected. The problem should be located and repaired before power is applied again.

The rear power connectors include spare fuses that can be used in any of the locations listed.

Table 5-1. AC Line and On-Board Fuses

Location	Fuse Value
Rear AC Line Connector(s)	5 X 20 mm, 1.6A slo-blow, 250V
Control Card, F1100	5 X 20 mm, 1.6A slo-blow, 250V
I/O Card(s) F1 and F2	5 X 20 mm, 1.6A slo-blow, 250V



**WARNING: Dangerous voltages are present at the rear AC power connector and on the Power Supply Card. Take precautions to prevent electric shock: Do not touch exposed wires or connecting pins.**

## **Diagnostic Software**

Diagnostic software that runs on a Windows PC is supplied on a floppy, usually inside the front cover of this manual or the manual for the software. Using the software, you can perform routine checks of system health, and you can reconfigure or test the router. Please refer to the diagnostic software manual accompanying this manual for instructions.

## **Adjustments**

There are no adjustable components in the NV3064 Router.

## Troubleshooting and Repair

Many system troubles are caused by easily-corrected errors, such as poor quality or missing input or reference signals, incorrect board jumper settings, and the like. Table 5-2 lists common problems and their solutions in approximately the most likely order of occurrence. Try troubleshooting the system yourself, and if you are not successful, call NVISION Technical Support as explained near the front of this manual.

In the event that a problem is caused by a bad circuit board, swapping the bad board with a replacement circuit board is the quickest solution. If you need to order replacement boards or other components, see “Ordering Replacement Assemblies” on page 5-8.

**Table 5-2. System Troubleshooting**

Symptom	Possible Causes and Solutions
System or module not lighting up.	<p>Verify presence of power at the AC mains.</p> <p>Check that the module is fully seated in the frame.</p> <p>Check fuses. See “Fuses” on page 5-4.</p>
Audio pops or ticks on one or two outputs or in blocks of 8 outputs (synchronous routers only).	<p>AES audio input source(s) is not locked to the AES House Reference. All inputs to the router should be locked to AES house reference. Any unlocked input will exhibit ticks in the signal after it passes through the router.</p> <p>I/O phase alignment circuitry fault. Swap I/O boards and check whether the fault moves with the board to a different block of 8 outputs.</p>
Audio always pops when switched, or periodic ticks are heard in all outputs (synchronous routers only).	<p>AES Reference input is unstable or not locked to video. Make sure a quality reference locked to video is used.</p> <p>AES audio input sources are not locked to the AES House Reference. All inputs to the router should be locked to AES house reference.</p> <p><b>NOTE:</b> Audio popping is to be expected with asynchronous routers, since signals are not phase aligned before they are switched.</p> <p>(continued -&gt;)</p>

**Table 5-2. System Troubleshooting (Continued)**

<b>Symptom</b>	<b>Possible Causes and Solutions</b>
Intermittent signal on one or two outputs.	<p data-bbox="824 306 1382 338">Check cable continuity while wiggling the cable.</p> <p data-bbox="824 375 1321 407">Check that cables are securely connected.</p> <p data-bbox="824 445 1406 579">Check cable terminations, especially for balanced cables. If only one of the two leads of a balanced connector is connected, the signal may be intermittent.</p> <p data-bbox="824 617 1409 827">Possible bad I/O module or Crosspoint module. Swap I/O modules to see if the trouble follows the module, if so replace the bad I/O module. If the I/O modules check out OK, the Crosspoint module is suspect and should be swapped with a known good module.</p> <p data-bbox="824 865 1409 1066">Some audio faults can be traced to the Control module. Audio faults caused by the Control card can be caused by intermittent crosspoint switches to the wrong source. In synchronous AES routers, the control module provides the system clocks. Faults in these clocks are usually global in nature.</p> <p data-bbox="824 1104 1409 1209">If all cables, terminations, and modules check out OK, the problem could be a motherboard or backplane connector or trace. Call Technical Support.</p>
Intermittent or missing signals on all outputs.	<p data-bbox="824 1236 1409 1268">Possible bad Crosspoint Matrix module. Replace.</p> <p data-bbox="824 1306 1409 1583">Possible low voltage on Power Supply or Crosspoint Matrix module. Check power test points on Power Supply (first) and Crosspoint module (second). Correct voltages are silkscreened next to test points. Voltages at Power Supply test points may be higher than expected in lightly loaded systems. Replace any modules having low voltage readings.</p>
Intermittent or missing signals confined to outputs 1-32 or 33-64.	<p data-bbox="824 1608 1409 1705">Possible low voltage or other problem on I/O module. Swap I/O modules and see if the problem follows the module. Replace the bad module.</p>

## Ordering Replacement Assemblies

To order spare or replacement assemblies:

1. Call NVISION Customer Support at the telephone number in the front of this manual under the heading “Technical Support.”
2. Our support representative will assign you a Return Material Authorization (RMA) number and fax you a Return Authorization Form (Figure 5-5). **Do not return equipment without first receiving an RMA#.** The form indicates the type of service you are requesting and the urgency of the repair and return shipment.
3. Package the board or assembly in an antistatic bag and place it in a shipping box with plenty of padding material to prevent damage.
4. Address the package using the Shipping Address listed in the front of this manual under the heading “Technical Support.”
5. Send the equipment to NVISION using the shipper and shipping method you prefer. You will pay to ship the equipment to us, and we will pay return freight to you.
6. The factory will use the Return Authorization Form to track receipt of the equipment from you and to note repair or replacement information. If the equipment is out of warranty, we will estimate the cost of repair and call you for authorization.
7. When repair or replacement is complete, we will return ship the equipment to you at our expense if it is in warranty. For out of warranty equipment we charge a shipping and handling fee. The normal shipping method is Second Day unless you specify that you need Next Day or Next Day A.M. shipping due to urgency.
8. NVISION will invoice you the amount quoted if the repair or replacement part is for out of warranty equipment.

**NVISION, INC. RETURN AUTHORIZATION FORM**

RMA #

WARRANTY #

Date		Time	:
Originator		Customer Number	
Contact		Telephone Number	( ) -

Customer Name	
Address	
City	
State	
Zip Code	-

Product Type(s)	
<i>Preliminary Diagnosis</i>	
Special Conditions	

**SERVICE PLAN:**

Repair       Exchange       Loaner      Loan Order #:

Return Via       Next Day A.M.       Next Day       2<sup>nd</sup> Day

Loaner Serial Number's

**INCOMING RECIEPT:**

Serial Numbers/Product	
Date Received	
Time	:
Received By	
Material Disposition:	<input type="checkbox"/> Q <input type="checkbox"/> Test      Credit Memo #:

**OUTGOING STATUS:**

Tested By	
Date	
Time	:

Diagnosis and Repair

**Figure 5-5. Typical Return Authorization Form (subject to change)**



## **Section 6:Notes**

This section of the manual includes Technical Bulletins, Application Notes, and any other special information that became available after the manual was printed. These items are inserted at the time the product is shipped and may include late-breaking important information.

You may also use this section for inserting your own notes about the product or your specific installation.

## **Introduction**

Any notes or other late-breaking information will be inserted following this page.

# Index

## A

AC Line Connection **2-10**  
 AC Power Connection **2-13**  
 Adjustments **5-5**  
 AES Ref Input **2-10**  
 AES Ref Termination Jumper **2-6**  
 Asynchronous I/O Card Jumpers **2-7**

## B

Board Installation **2-4**

## C

Cable Connections **2-10**  
 Card Installation **2-4**  
 Configuring the Router **2-15**  
 Control Card, Theory of Operation **4-4**  
 Control Connectors **2-10**  
 Control Module **5-2**  
 Control Panels **3-1**  
 Crosspoint Card, Theory of Operation **4-5**  
 Crosspoint Matrix Module **5-3**  
 Customer Service **xiv**

## D

Diagnostic Connectors **2-10**  
 Diagnostic Software **5-5**

## F

Frame Installation **2-2**  
 Fuses **2-14, 5-4**

## G

General **1-1**

## I

I/O Card Jumpers **2-7, 2-8**  
 I/O Cards, Theory of Operation **4-4**  
 I/O Module **5-3**  
 Input Connections, Output Connections **2-10**  
 Installation **2-1**

- AC Power **2-13**
- Cable Connections **2-10**
- Cards **2-4**
- Configuration Using UniDiag **2-15**
- Frame **2-2**
- Fuses **2-14**
- Jumper Settings **2-5**
- Phoenix Connectors **2-12**
- Serial Ports **2-12**
- Tools and Materials Required **2-2**

 Installing the Router **2-2, 2-15**

## J

Jumper Settings **2-5**

## L

LEDs, Meaning of Colors **5-2**  
 Line Voltage Jumper **2-5**

## M

Maintenance **5-2**

- Adjustments **5-5**
- Control Module Indicators **5-2**
- Crosspoint Module Indicators **5-3**
- Diagnostic Software **5-5**
- Fuses **5-4**
- I/O Module Indicators **5-3**
- Ordering Replacement Assemblies **5-8**
- Power Supply Module Indicators **5-4**
- Routine **5-2**
- Troubleshooting and Repair **5-6**

 Matrix Crosspoint Card, Theory of Operation **4-5**  
 Module Installation **2-4**

## N

Node Bus Connector **2-10**

## O

Operation **3-1**  
Overview, System **4-2**

## P

Phoenix Connectors, Connecting to **2-12**  
Power Selection Jumper **2-5**  
Power Supply Module **5-4**  
Power Supply, Theory of Operation **4-6**  
Preface **vii**  
Product **1-3**

## Q

Quick Start **vii**

## R

Reference Input Connections **2-10**  
Repair **5-6**  
Replacement Assemblies, Ordering **5-8**  
Return Material Authorization Form **5-8**

## S

Serial Port Connector Pin-Outs **2-12**  
Software **5-5**  
Support **xiv**  
Synchronous I/O Card Jumpers **2-8**  
System Overview **4-2**

## T

Technical Support **xiv**  
Theory of Operation **4-1**  
    Control Card **4-4**  
    Crosspoint Card **4-5**  
    I/O Cards **4-4**  
    Overview **4-2**  
    Power Supply **4-6**  
Tools and Materials for Installation **2-2**  
Troubleshooting and Repair **5-6**

## U

UniDiag **2-15**  
Universal Control Card, Theory of Operation **4-4**  
Universal Control Module **5-2**  
Unpacking Instructions **1-2**

## V

Video Ref Input **2-10**  
Voltage Selection Jumper **2-5**

## Y

Y2K Statement **viii**